

I 125W1B

Peso Kg/m 16.80  
Weight Kg/m 16.80

Ventilazione forzata  
Forced ventilation

Lung. campione mm 300  
Sample length mm 300

Velocità dell'aria in uscita (m/sec) 6.0  
Outgoing air speed (m/sec) 6.0

Rt °C/W 0.047

Dimension H on request

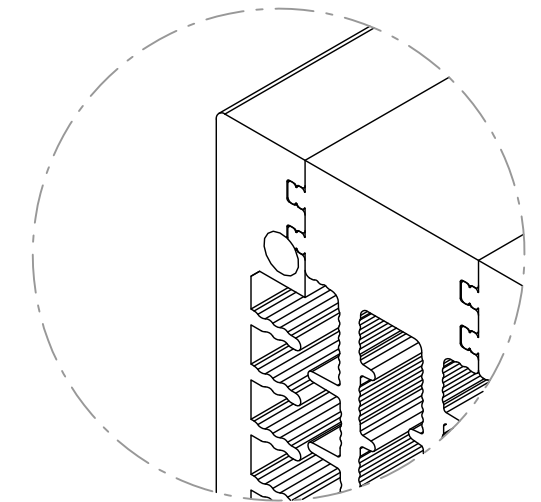
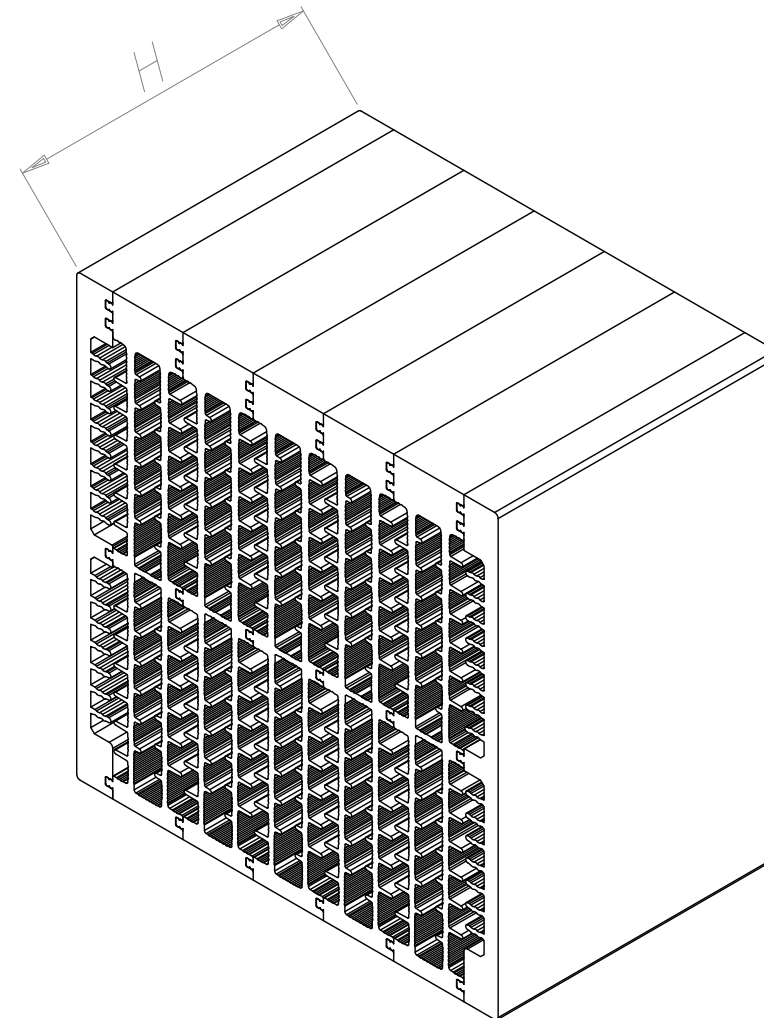
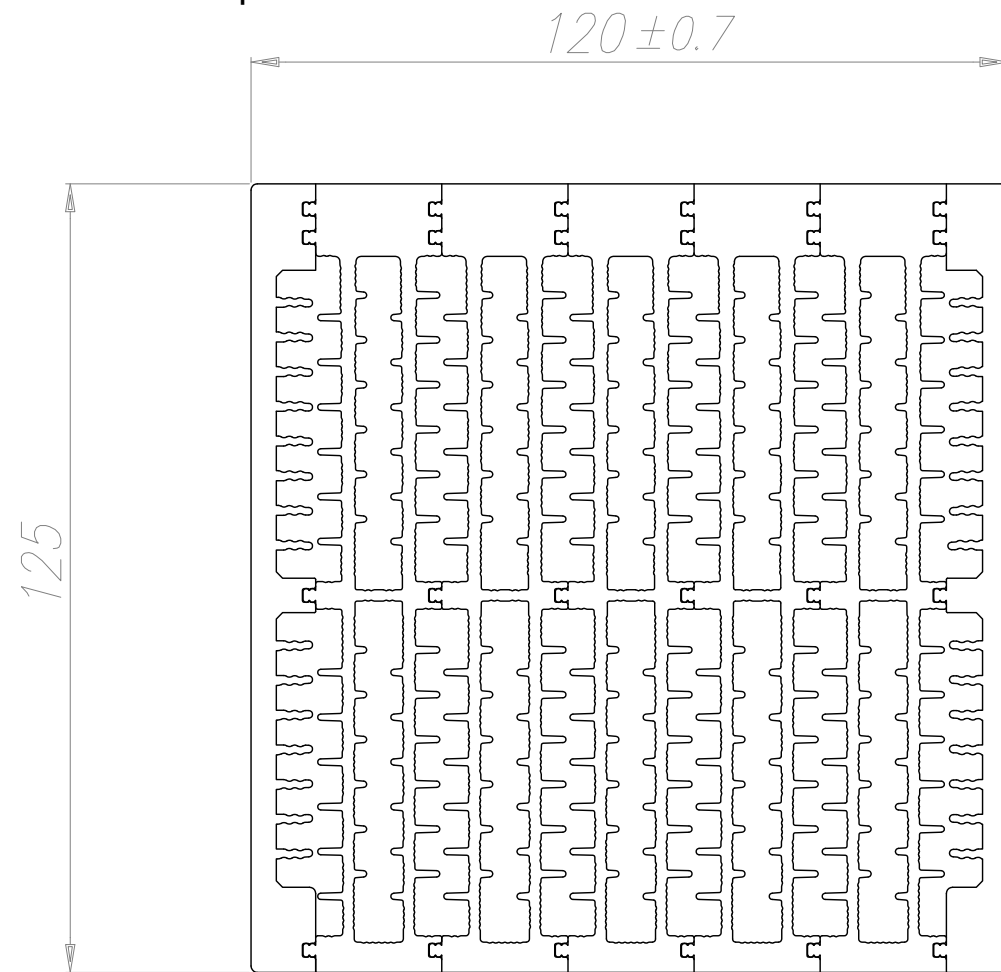

Su richiesta foratura M3x8mm per fissaggio ventola 120x120

On request holes M3x8mm for fan 120x120

**ALL SIZES ARE SUBJECT THE TOLERANCE OF EXTRUSION**

UNLESS OTHERWISE INDICATED, PIECES NOT IN COMPLIANCE WITH THE GENERAL PRESCRIBED TOLERANCES SHOULD NOT AUTOMATICALLY BE REFUSE WHEN THE FUNCTIONALITY OF THE PIECES HAS NOT BEEN COMPROMISED.

**TUTTE LE DIMENSIONI SONO SOGGETTE ALLE TOLLERANZE DI ESTRUSIONE**

SALVO INDICAZIONE CONTRARIA I PEZZI NON CONFORMI ALLE TOLLERANZE GENERLI PRESCRITTE NON DEVONO ESSERE AUTOMATICAMENTE RIFIUTATI QUANDO LA FUNZIONALTA' DEL PEZZO NON RISULTA COMPROMESSA.

Notes:

---

---

---

---

---

---

---

---