

**A**

<b>A31M</b>	
Peso Kg/m Weight Kg/m	1.10
Rt °C/W	4.50
Lung. campione mm Sample length mm	100

□ Cava per M4  
□ Groove for screw M4

**TECNODAL**  
www.tecnodal.it

**B**

<b>A47M</b>	
Peso Kg/m Weight Kg/m	1.30
Rt °C/W	2.50
Lung. campione mm Sample length mm	100

ONLY ON REQUEST

□ Cava per M4  
□ Groove for screw M4

**TECNODAL**  
www.tecnodal.it

**C**

<b>A60M</b>	
Peso Kg/m Weight Kg/m	1.54
Rt °C/W	3.00
Lung. campione mm Sample length mm	100

□ Cava per M4  
□ Groove for screw M4

**TECNODAL**  
www.tecnodal.it

**D**

<b>AX60M</b>	
Peso Kg/m Weight Kg/m	2.15
Rt °C/W	2.60
Lung. campione mm Sample length mm	100

**TECNODAL**  
www.tecnodal.it

**A75M**

Peso Kg/m **2.55**  
Weight Kg/m

Rt °C/W **2.75**

Lung. campione mm **100**  
Sample length mm

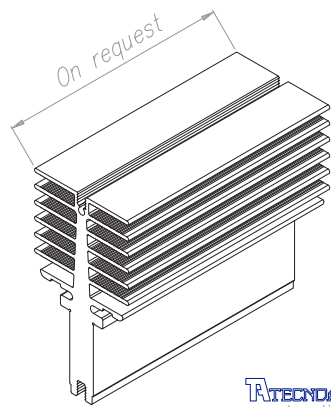
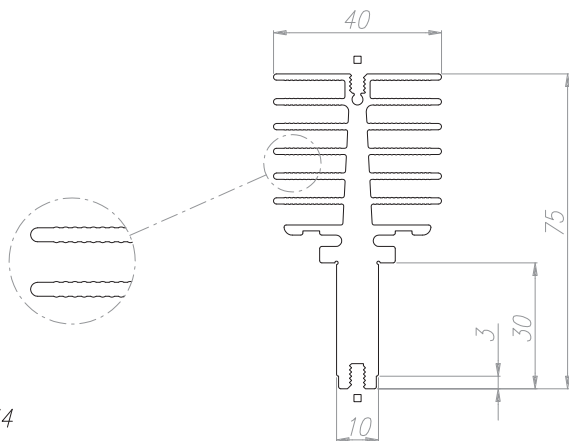

**TECNDAL**  
www.tecnoal.it

- Cava per M4
- Groove for screw M4

**A**

**AX75M**

Peso Kg/m **2.52**  
Weight Kg/m

Rt °C/W **2.30**

Lung. campione mm **100**  
Sample length mm

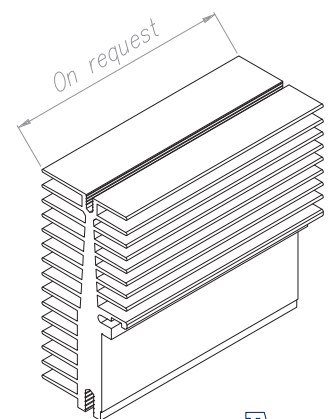
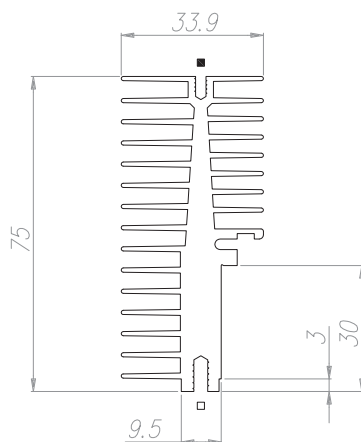

**TECNDAL**  
www.tecnoal.it

- Cava per M3 / Groove for screw M3
- Cava per M4 / Groove for screw M4

**B**

**A82M**

Peso Kg/m **2.55**  
Weight Kg/m

Rt °C/W **1.90**

Lung. campione mm **100**  
Sample length mm

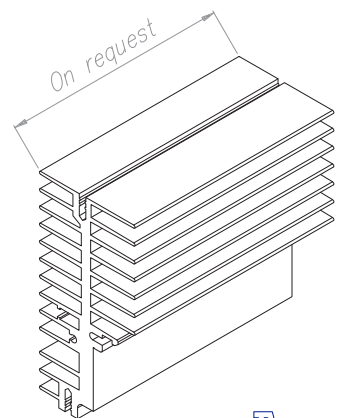
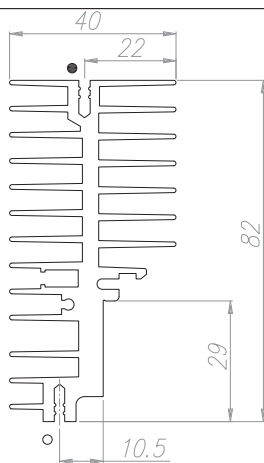

**TECNDAL**  
www.tecnoal.it

- ○ Cava per autofilettante
- ○ Groove for Self-tapping

**C**

**MOLLE PER IL FISSAGGIO DEL COMPONENTE SU DISSIPATORI SERIE TECNOCLIP**  
**CLIPS FOR ASSEMBLY ELECTRONICS COMPONENTS ON HEATSINKS SERIES TECNOCLIP**

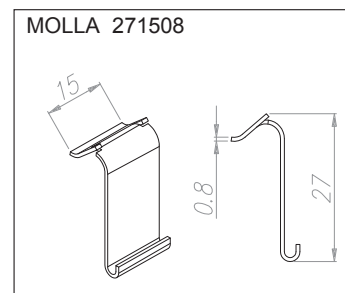
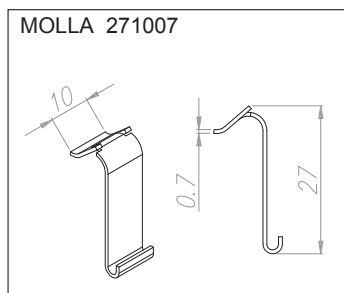
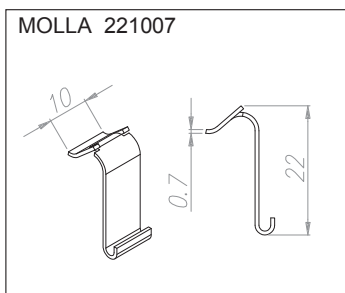

**TECNDAL**  
www.tecnoal.it

**D**